

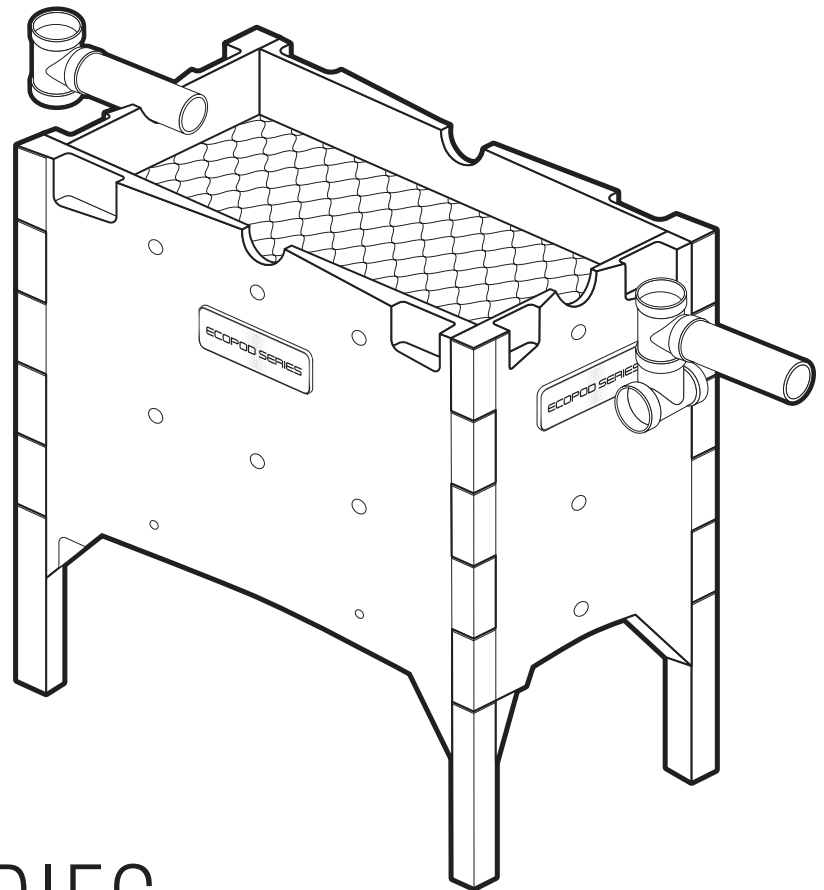

A wholly owned subsidiary of Infiltrator Water Technologies, LLC



ECOPOD-N[®] SERIES FIXED FILM WASTEWATER TREATMENT SYSTEM

INSTALLATION, OPERATION AND MAINTENANCE MANUAL



NOTE! To the installer: Please make sure you provide this manual to the owner of the equipment or to the responsible party who maintains the system.

TABLE OF CONTENTS

Distributor and Homeowner Notes	3
ECOPOD-N® Treatment Systems Notice	4
Introduction	5
Process Description	5
Homeowner Care and Operation Instructions	5-6
Safety Warnings	6
Solids Removal	6
Seasonal Use Guidelines	6-7
Sampling Requirements	7
Taking Effluent Samples	7-8
Installation Instructions	9-12
Troubleshooting Guide	13
Component Replacement Procedure	13-14
General Comments	14
ECOPOD-N Unit Specifications	14
ECOPOD-N Electrical Requirements	14
ECOPOD-N Dimensions	15
Standard Details Drawings	16-20
Regenerative Blowers	21-23
Data Plates	24
Service Policy	25
Warranty	28

DISTRIBUTOR AND HOMEOWNER NOTES

1. The Delta Treatment Systems Model E50N has been tested by NSF International and conforms to NSF/ANSI Standard #40 & #245, class 1 effluent requirements. All other E series models are certified based on provisions in the standard for certification of a series of plants of the same model varying only in rated treatment capacity and materials of construction.
2. State and/or local regulations govern the installation and use of individual Aerobic Wastewater Treatment Systems and must be complied with.

Consult your local Sanitarian/Environmentalist prior to installation.

HOMEOWNER RECORDS	
S/N: _____	DATE: _____
INSTALLED BY: _____	
DISTRIBUTOR: _____	

This booklet provides operations, installation and warranty information on the **TREATMENT PLANT ONLY**. Other components that you may have, such as dosing equipment, drip irrigation or other components, require additional operations booklets and carry separate warranties.

Be sure that you have all of the correct booklets for each of the component pieces in your system.

Contact your installer or call 1-800-219-9183.

ECOPOD-N® TREATMENT SYSTEMS NOTICE

This home is served by an Individual Wastewater Treatment System. This system will serve you well only if it is properly maintained. Your system comprises

Your system is located

You should not build or fill over this area, or allow heavy traffic. Do not allow water to stand over this area, avoid using strong chemicals, cleaning fluids, etc., which will kill helpful bacteria in the system. You should also avoid flushing grease, food scraps, cigarette butts, sanitary napkins, and other inorganic waste down the drain.

You should have your system serviced (pumped out) every 3 to 5 years. Your service technician can advise you if you need more frequent or additional service.

To have your system serviced, or for additional information, contact _____ at _____ .

All of the details regarding system operation can be found in your homeowner's manual, which you should have received at installation. If you did not receive a copy, call 1-800-219-9183 and we will send you one at no charge.

Keep a Record of Service Below:

DATE	SERVICE PERFORMED	SERVICE TECHNICIAN

INTRODUCTION

A WORD ABOUT YOUR DELTA AEROBIC WASTEWATER TREATMENT SYSTEM AND HOW IT WORKS

The ECOPOD-N Fixed Film Wastewater Treatment System that you have purchased produces high quality water suitable for various disposal methods. It is used to enhance your on-site wastewater disposal system. You can be proud that in purchasing your ECOPOD-N System, with a minimum amount of maintenance you can directly contribute to a cleaner, safer environment.

All wastewater treatment systems of this type work by using bacteria that nature has provided. By pumping air into the system, the bacteria grow and thrive in much larger amounts than would occur naturally. The overpopulation of bacteria speeds up the process of breaking down domestic wastewater, making it safe for release into the environment. This entire process takes place within the walls of your specially designed, self-contained ECOPOD-N Treatment System.

The result of this process is a clear, odorless discharge, which meets or exceeds state water quality standards.

By following the few simple steps that you will find in this manual, your ECOPOD-N Fixed Film Wastewater Treatment System will provide you with years of service and the knowledge that you are doing your part to protect public health, our groundwater, lakes, rivers, and streams.

The ECOPOD-N Fixed Film Wastewater Treatment System may be only one of several components required by your health department to provide a complete on-site system.

CALIFORNIA PROPOSITION 65 WARNING:

⚠ WARNING This product and related accessories contain chemicals known to the State of California to cause cancer, birth defects or other reproductive harm.

PROCESS DESCRIPTION

Water enters a pretreatment/settling tank similar to conventional septic tanks. In this tank, debris and settleable solids settle to the bottom and are decomposed by anaerobic bacteria.

The effluent enters the ECOPOD-N Fixed Film Wastewater Treatment System from the primary tank where it is introduced into an oxygen rich environment. In this oxygen rich environment, a colony of bacteria, called the biomass, develops and is capable of digesting (breaking down) biodegradable waste into carbon dioxide and water. This is a continuous process as long as the biomass is supplied with incoming wastewater and oxygen. The ECOPOD-N is a specially designed containment device that houses an engineered plastic media specifically designed to treat domestic wastewater. The ECOPOD-N is submerged in a tank of liquid, which operates as a dilution zone. An external air compressor is connected to the tanks to provide the necessary air to the system. There are no moving mechanical parts or filters in the ECOPOD-N.

In this system, conditions are favorable only to attached growth bacteria. This means that the most common disadvantages of other types of systems are eliminated. No rising sludge, floating sludge or washouts can occur.

In addition to CBOD and TSS reduction, ammonia nitrogen is one of the contaminants. Wastewater nitrification of the ammonia and denitrification of nitrates occur within the bacteria masses. A 50%+ removal rate of total nitrogen is common without any type of recirculation or cycling of the blower.

HOMEOWNER CARE AND OPERATION INSTRUCTIONS

The ECOPOD-N Fixed Film Wastewater Treatment System has been designed and built to provide long term, reliable and efficient service.

Once the unit has been installed (see installation instructions), the unit will operate with a minimum amount of attention.

Please reference the system's Data Plates that are located on the tank, air pump, and the alarm panel in the event that a problem arises or service is required.

The following should be accomplished as checks for system failure:

Daily

- Observe the warning device, which comes on when the power to the air pump has been interrupted, when the air supply system has malfunctioned, or there is a high water level in the treatment plant. If the alarm is activated, check for a blown fuse or thrown circuit breaker. Check the air pump to be sure it is operating. Once accustomed to the soft humming sound of a properly operating unit, any unusual noise is an indication of malfunction. If an unusual noise is detected or total failure is observed, call an authorized Delta dealer/distributor.

Weekly

- Check the treatment plant for offensive odor. If such a condition should develop, call an authorized Delta dealer/distributor.

Every 3 Months

- **The air filter on the air pump should be cleaned.** Rinse with warm water if necessary. (See installation instructions.) Do not use oil or other solvents.

Every 6 Months

- Inspect and make any necessary adjustments to mechanical and electrical components.
- Inspect effluent quality's color, turbidity and check for any odor.
- Take a sample from the reactor tank to check the sludge level described in the "Solids Removal" section.
- **The homeowner must be notified in writing if any improper operation is observed and cannot be corrected at the time of service.**

Note: To keep maintenance to a minimum and ensure high effluent quality, see the next section.

The following should not be used or disposed of into the system:

- Greases, fats, oils, pesticides, herbicides, or any other toxins.
- Garbage disposal should be used sparingly. Dispose of food waste, grease, etc., in the solid waste bin. Food waste represents additional loading the Fixed Film Wastewater Treatment System would have to digest, increasing pump-out intervals.
- Paints, household chemicals, automobile fluids, etc. – do not discard mop water into the system.
- Nonbiodegradable items such as cigarette butts, disposable diapers, feminine hygiene products, condoms, hair, coffee grounds, rags, paper towels, bandages, latex, plastic or metallic objects, etc.

- Wash loads must be spread out over the week. Once a week multiple loads or half loads are not recommended.
- Citrus products, oranges, lemons, grapefruit, etc.
- Additives for septic systems – they do more harm than good.
- Hydraulic overload due to excessive water from other sources.
- Home brewery waste, strong medicines, antibiotics and antibacterial soaps should be avoided.
- Strong disinfectants or bleaches. Laundry products such as Lysol, Pine-Sol, Tidy Bowl, or discharge from water softeners.
- Recommended detergents are powdered, low-sudsing, low phosphates and biodegradable washing soda ingredients such as Gain, Arm & Hammer, Fresh Start, and Dash Bright. Fabric softener dryer sheets are recommended.
- Recommended cleaning products are non-chlorine, biodegradable and nontoxic such as Ivory & Sunlight dish washing liquids, Cascade & Sunlight powdered dishwasher detergents, Comet & Biz powdered cleaners, baking soda.

SYSTEMS REQUIRING PUMPOUTS DUE TO THE ABOVE VIOLATIONS ARE NOT COVERED BY THE WARRANTY.

The ECOPOD-N Fixed Film Wastewater Treatment System is designed to handle domestic wastewater; nothing else should go into it. For anything other than domestic wastewater, contact Delta Treatment Systems.

Safety Warnings

THE PROPER OPERATION OF THIS OR ANY OTHER HOME SEWAGE SYSTEM DEPENDS UPON PROPER ORGANIC LOADING AND THE LIFE OF THE MICROORGANISMS INSIDE THE SYSTEM. DELTA IS NOT RESPONSIBLE FOR THE IN-FIELD OPERATION OF A SYSTEM, OTHER THAN THE MECHANICAL AND STRUCTURAL WORKINGS OF THE PLANT ITSELF. DELTA CANNOT CONTROL THE AMOUNT OF HARSH CHEMICALS OR OTHER HARMFUL SUBSTANCES THAT MAY BE DISCHARGED INTO THE SYSTEM BY THE OCCUPANTS OF A HOUSEHOLD; WE CAN ONLY PROVIDE A COMPREHENSIVE OWNER'S MANUAL THAT OUTLINES SUBSTANCES THAT SHOULD BE KEPT OUT OF THE SYSTEM.

HYDRAULIC OVERLOADING (FLOWS IN EXCESS OF DESIGN FLOW) MAY CAUSE THE SEWAGE TREATMENT SYSTEM NOT TO PERFORM TO THE FULLEST CAPABILITIES.

ANTS HAVE BEEN SHOWN TO BE DESTRUCTIVE TO THE AIR PUMP. REGULAR CARE SHOULD BE TAKEN TO PREVENT INFESTATION OF ANTS NEAR THE SYSTEM. DAMAGE OR DESTRUCTION BY ANTS IS NOT COVERED UNDER MANUFACTURER'S WARRANTY.

YOUR STATE OR LOCAL HEALTH DEPARTMENT MAY REQUIRE OTHER PIECES OF EQUIPMENT TO FUNCTION SEPARATELY OR IN CONJUNCTION WITH EQUIPMENT MANUFACTURED BY DELTA TREATMENT SYSTEMS. DELTA IS NOT RESPONSIBLE FOR THE MECHANICAL OR ELECTRICAL SAFETY OF EQUIPMENT IT DOES NOT MANUFACTURE OR SUPPLY WITH ITS FIXED FILM WASTEWATER TREATMENT SYSTEM. PARTICULAR CARE SHOULD BE USED IN EVALUATING THE ELECTRICAL OR MECHANICAL SAFETY OF EQUIPMENT MANUFACTURED BY OTHERS. THIS MAY INCLUDE BUT IS NOT LIMITED TO ELECTRICAL CONTROL PANELS OR AIR PUMPS.

IF ELECTRICAL SERVICE HAS NOT BEEN INSTALLED FOR CHECKING AIR DISTRIBUTION SYSTEM DURING INSTALLATION, AND IF AN EXTENSION CORD IS USED TO TEST THE AIR PUMP, NEVER LEAVE THE EXTENSION CORD PLUGGED IN. REMOVE IT AFTER TESTING IS COMPLETED.

DUE TO A POSSIBLE FIRE HAZARD, DO NOT PLUG INTO SERVICE EQUIPMENT ON POWER POLE AND DO NOT USE EXTENSION CORDS. ALL ELECTRICAL WORK PERFORMED BY THE INSTALLER OR OTHERS MUST BE IN ACCORDANCE WITH THE NATIONAL ELECTRICAL CODE AND LOCAL CODES.

SOLIDS REMOVAL

The ECOPOD-N Fixed Film Wastewater Treatment System is designed to provide years of trouble-free operation.

Determination of the need for solids removal can be done through a simple test. A one quart sample should be pulled from the reactor tank and can be done so through the 4" sample port. Allow the sample to settle in a clear one quart jar for one hour. If the solids content exceeds 25 percent of the total volume after settling or more than 13 inches of sludge, the treatment plant should be pumped out. Call your local authorized sewage disposal service to have the tank contents pumped out and disposed of properly.

The method of pumping out should be as follows:

- Remove all of the solids from both the reactor tank and primary tank.
- The air pump should be in the off position.

After the pumpout process is complete, fill the tank with fresh water to normal operating level.

Refer to the "Installation Procedure" to get the treatment plant back into operation.

Should indication of improper operation be observed at any time, contact your local authorized Delta dealer/distributor.

NOTE: THE COST ASSOCIATED WITH PUMPING THE TREATMENT SYSTEM IS NOT COVERED UNDER WARRANTY AND IS NOT INCLUDED IN THE SERVICE POLICY.

SEASONAL USE GUIDELINES OF ECOPOD-N FIXED FILM WASTEWATER TREATMENT SYSTEM

These guidelines are for conditions as outlined below and apply for systems that are not in use for periods of time indicated. Site conditions not covered by the following must be forwarded to Delta for recommended guidelines to meet the particular site conditions.

1. System not in use for more than one month and less than three months. Electrical power is left on and there are no frost conditions.
 - Leave air pump on and system running.
2. System not in use more than three months. Electrical power is turned off and there are not frost conditions.
 - Remove all materials and liquid from tank.
 - Refill with clean water.
 - Turn off air pump.
3. System not in use more than three months. Electrical power is on and there are not frost conditions.
 - Leave air pump on and system running; OR
 - Remove all material and liquid from tank.
 - Refill with clean water.
 - Turn off air pump.

4. System not in use. Electrical power is turned off and there are frost conditions.
 - Remove all material and liquid from tank.
 - Turn off air pump.
 - If high groundwater is present, fill with clean water.
 - If no groundwater is present, leave tank empty.

⚠ UNDER NO CIRCUMSTANCES SHOULD THE AIR PUMP BE TURNED OFF FOR MORE THAN A FEW DAYS WITHOUT REMOVING TANK CONTENTS.

SAMPLING REQUIREMENTS

An ECOPOD-N Fixed Film Wastewater Treatment System properly operated and maintained should provide the following effluent quality of:

Biochemical oxygen demand 5 day average (BOD₅) of less than 30 mg/l (or ppm)

Suspended solids of less than 30 mg/l (or ppm)

Volatile suspended solids of less than 30 mg/l (or ppm)

pH of 6.0 to 9.0

Dissolved oxygen 1.5 to 3.0 mg/l (or ppm)

Taking Effluent Samples

Samples must be taken in the effluent discharge line or an effluent pump or after the disinfection device. We recommend allowing the effluent to flow through the discharge pipe for a minimum of 2 minutes before taking the sample. This will allow any solids to be flushed out that might have accumulated in the discharge pipe. Please find attached drawing of a sample port.

SAMPLING SHOULD BE TAKEN BY A LOCAL CERTIFIED TESTING LABORATORY OR BY FOLLOWING THEIR PROCEDURES. THE FOLLOWING RECOMMENDED GUIDELINES MAY BE USED IF LOCAL PROCEDURES ARE NOT AVAILABLE.

1. Biochemical Oxygen Demand (BOD)

Samples for BOD analysis may degrade significantly during storage between collection and analysis, resulting in low BOD values. Minimize reduction of BOD by analyzing the sample promptly or by cooling it to near freezing temperature during storage. However, even at low temperature, keep the holding time to a minimum. Warm the chilled samples to 20°C before analysis; some storage time can be used to accomplish this conveniently.

 - Grab Samples: If analysis is begun within two hours of collection, cooling is unnecessary. If analysis is not started within two hours of sample collection, keep sample at or below 4°C from the time of collection. Begin analysis within six hours of collection; when this is not possible because the sampling site is distant from the laboratory, store at or below 4°C and report length and temperature of storage to the lab. In no case, start analysis more than 24 hours after grab sample collection. When samples are to be used for regulatory purposes, make every effort to deliver samples for analysis within six hours of collection.
2. Total Suspended Solids (TSS)

Use resistant-glass or plastic bottles, provided that the material in suspension does not adhere to container walls. Begin analysis as soon as possible because of the impracticality of preserving the sample. Refrigerate sample at 4°C to minimize microbiological decomposition of solids.

3. Phosphorus

If phosphorus forms are to be differentiated, filter samples immediately after collection. Preserve by freezing at or below -10°C. Add 40 mg/HgCl₂/L to the samples, especially when they are to be stored for long periods. Do not add either acid or 2CHCl₃ as a preservative when phosphorus forms are to be determined. If total phosphorus alone is to be determined, add 1 mL concentration HCL or freeze without any additions.

Do not store samples containing low concentrations of phosphorus in plastic bottles unless kept in a frozen state because phosphates may be adsorbed onto the walls of plastic bottles.

Rinse all glass containers with hot diluted HCL, then rinse several times in distilled water. Never use commercial detergents containing phosphate for cleaning glassware used in phosphate analysis.

4. Ammonia Nitrogen

Most reliable results are obtained from fresh samples. Destroy residual chlorine immediately after sample collection to prevent its reaction with ammonia. If prompt analysis is impossible, preserve samples with 0.8 mL concentration H₂SO₄/L sample and store at 4°C. The pH of the acid-preserved samples should be between 1.5 and 2. Some wastewater may require more concentration H₂SO₄ to achieve this pH. If acid preservation is used, neutralize samples with NaOH or KOH immediately before making the determination.

SAMPLE PROCEDURES:

1. PRIOR TO TAKING SAMPLE HAVE ECOPOD PLANT DISCHARGE EFFLUENT FOR UP TO 4 MINUTES BY FLUSHING TOILETS AND/OR USE GARDEN HOSE TO FLUSH OUT SAMPLE PORT.
2. INSERT SAMPLE COLLECTING BOTTLE TO COLLECT ONLY EFFLUENT THAT IS CASCADING OVER THE CASCADING EDGE.
3. HANDLE, STORE, AND TRANSPORT SAMPLES AS SPECIFIED BY POLICIES AND PROCEDURES PROVIDED BY THE TESTING LABORATORIES.

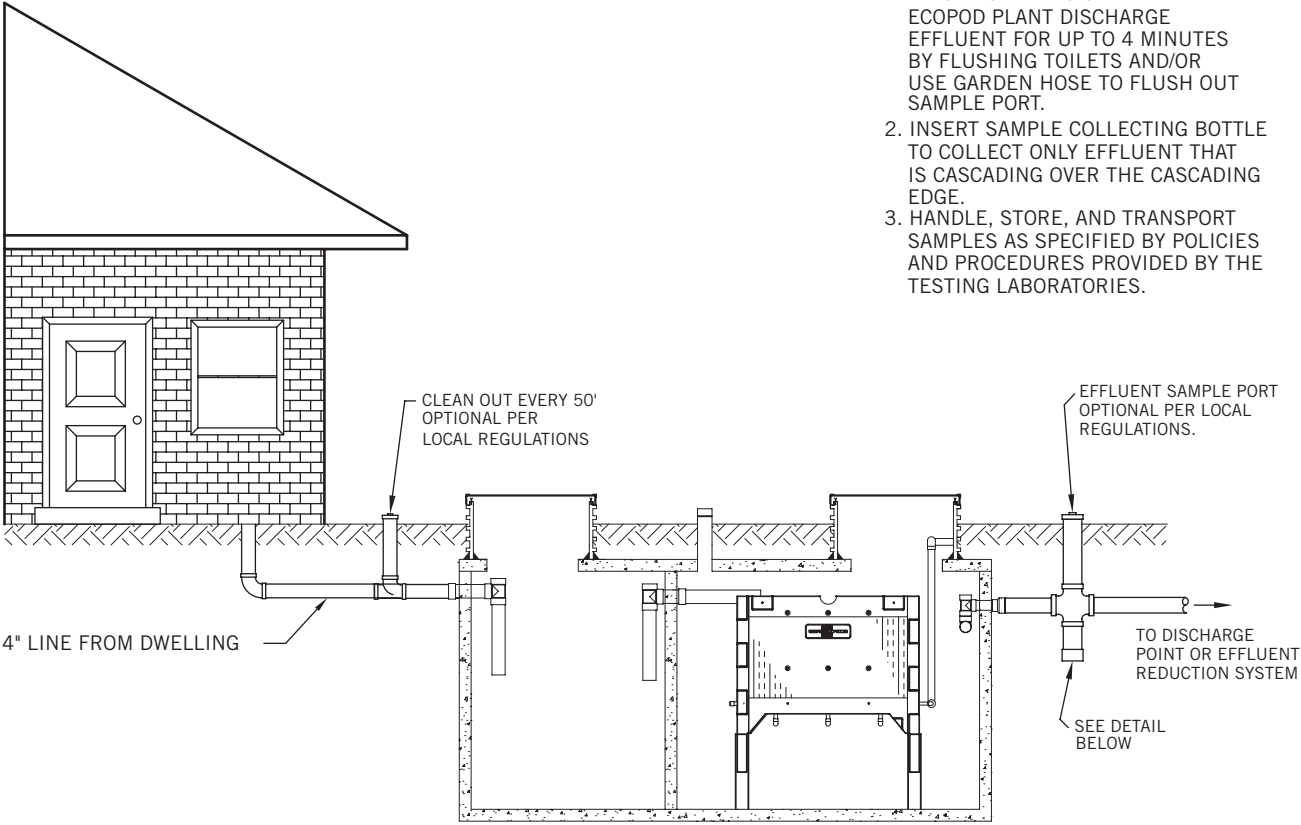

EXAMPLES OF SAMPLE PORTS

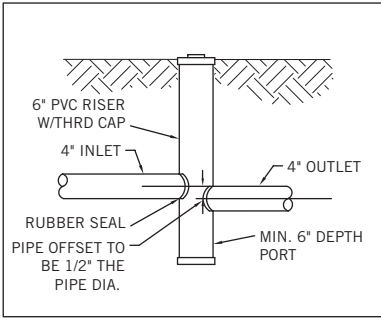
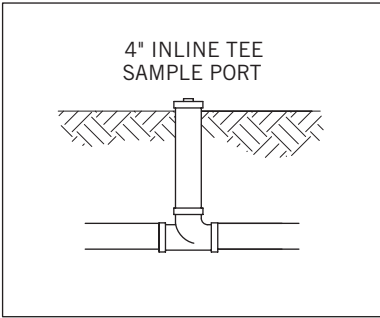
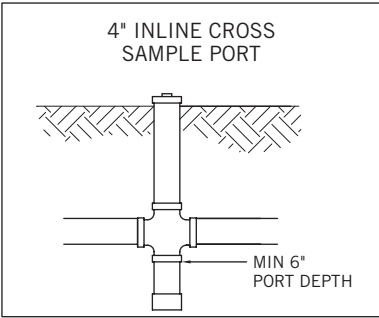

REV.	DATE	REVISION DESCRIPTION	BY



SAMPLE PORTS

COMPANY CONFIDENTIAL: INFORMATION CONTAINED HEREIN IS CONFIDENTIAL, IT IS THE PROPERTY OF DELTA TREATMENT SYSTEMS, IT IS TO BE USED SOLELY FOR THE PURPOSE PROVIDED, AND IT IS NOT TO BE DISCLOSED TO OTHERS WITHOUT THE PRIOR WRITTEN CONSENT OF DELTA TREATMENT SYSTEMS.

PLOT SCALE NTS	DRAWING NUMBER EP SAMP PORTS	DRAWN BY D.WRIGHT	DATE 10/31/07	SHEET OF 1 OF 1	REV A
-------------------	---------------------------------	----------------------	------------------	-----------------------	----------

INSTALLATION INSTRUCTIONS ONLY FOR USE BY CERTIFIED, LICENSED INSTALLERS

1. **Care must be taken offloading and unpacking components. Care must be taken not to damage fiberglass with forklift or any other offloading device. Check for any damaged components that may have happened in transportation and notify factory within 24 hours of delivery.**

Prepare an excavation, having a diameter approximately one foot larger than the tank and a depth that will allow approximately 3 inches of the inspection port to extend above normal ground level. Backfill with a 6 inch layer of sand or gravel if otherwise unable to provide a smooth, level, compact base. We recommend that the hole be roped off in some fashion to prevent injury to passersby.

2. Using lifting lugs provided, place the plant in the excavation so that the inlet and outlet line up with the sewer piping. The inlet line should slope down toward the plant and the outlet line should slope down away from the plant. The plant should be level within 1/2 inch, edge to edge.
3. Position inlet and outlet lines and make connections as necessary, depending upon construction materials. The inlet line should be inserted and glued into the inlet elbow and the discharge line should be inserted and glued into the outlet coupling.

Note: Open inspection port and make sure discharge tee assembly is level and centered in clarifier prior to attaching discharge piping. Fill the tank with water until water flows from the discharge before backfilling. Backfill around plant, up to the bottom of the discharge connections.

4. Do not install the air pump(s) in a low lying area where water may accumulate. The air pump should be installed near the control panel and within 100 ft. of the tank. The air pump can be installed outdoors or in a clean, well ventilated area, such as a tool room, garage, etc.
5. Mount the control panel in an area such that the alarm can be heard and be readily observed. A 3-wire grounded GFI circuit is required for safety. Install a disconnect switch near the panel to visually disconnect the control panel from the power source. All electrical work shall be done according to NEC and local code requirements. The control panel must be grounded. Connect the source ground wire to the ground location in the panel.
6. The control panel is rated for indoor and outdoor use and contains a fuse or circuit breaker for the air pump. An electrical malfunction in the air pump or wiring to the air pump will cause the fuse or circuit breaker to blow. The control panel also contains a pressure switch and visual and audible alarm. Loss of air pressure caused by air pump system malfunction or a high water level in the treatment plant will cause the alarm to sound and light to illuminate.
7. Attach control panel to suitable mounting surface using all four mounting holes on back of box. Use proper screws of sufficient length to ensure a secure and permanent mounting.
8. Control panel is rated for outdoor service; however, do not place it where it can be immersed in rising water or where runoff water such as from a roof will fall on it. Do not mount it where it is subject to wetting from sprinklers, hoses, etc.
9. The control panel must never be connected to a circuit that is not properly grounded. Never connect the unit to a nongrounded circuit. If there is doubt, have a qualified

electrician check for proper grounding. The control panel must be connected to a 20 amp maximum electric source equipped with a ground fault interrupter (GFI) circuit breaker. A standard circuit breaker can be replaced with a GFI circuit breaker which can be obtained from almost any store that sells electrical supplies.

10. After the control panel is properly mounted, connect conduit and install wiring as shown on drawings bound herein.
- 11a. Install float switch wire from the control panel to the treatment plant. Wire can be direct burial type UF 600 volt or can be installed in schedule 40 PVC conduit. Use type THWN, 600 volt if installed in conduit. Wire must be buried in accordance with NEC table 300-5. If in doubt, bury 24" deep. Keep sufficient distance or depth from air line to avoid confusion of pipes or damage to wiring during installation or repair of air piping. Connect to the float switch normally open contacts using underground rated compound filled wire nuts.
- 11b. If using the dual pressure switch panel, ignore 11a. To set the high level pressure switch that detects high water level in the unit, follow these instructions: Bring plant to operating water level with compressor turned on. Using properly sized screwdriver, turn high level alarm adjustment screw clockwise until alarm occurs. Then turn the screw counterclockwise until alarm stops.
12. Connect the pressure air tubing to the 1/8" barb-fitting in the air piping system. The air tubing should be protected by conduit as shown on drawing.
13. Install a minimum 2" schedule 40 PVC piping between air pump and treatment unit. A minimum of 12" ground cover is recommended.
14. Turn power on to control panel. Air pump should start.
15. Check air piping joints for leakage using a soapy water solution. Repair if necessary and then carefully backfill air line and inlet and discharge piping and cover plant to grade level.
16. Recheck water level in the tank.
17. Plant is ready to receive incoming sewage. No special start-up procedures are required. The process is naturally occurring and does not require any special additives.
18. Test alarm circuit by momentarily squeezing air tubing and allowing air pressure to decrease. This should take a few minutes. Alarm should occur. Release air tubing and alarm should stop. Lift float in tank to horizontal position. Alarm should occur. Release float. Alarm should stop. The audible alarm can be turned off by flipping the toggle switch on the panel front door to the left.
19. Close cover on control panel and lock if necessary.
20. In the event that a fuse blows, replace with time delay or slow blow, 125 volt minimum voltage rating and the same amp rating as the existing fuse.
21. The distribution of air to all droplines must be uniform. If the air flow is not evenly distributed, check the air pump or the main air line.
22. Spend time with your customer whenever possible. Review operation instructions. Be sure that the customer has a manual to keep. This saves valuable time avoiding return visits.
23. Retain these instructions for future reference.
24. **⚠ WARNING: CONTROL PANEL CONTAINS HIGH VOLTAGE AND MUST BE INSTALLED AND SERVICED ONLY BY QUALIFIED PERSONNEL.**

DELTA TREATMENT SYSTEMS RECOMMENDED INSTALLATION PROCEDURE

1. EXCAVATION:

Dig hole from the side for accurate sizing. This reduces the bridging distance between the tank and undisturbed soil and provides good support for inlet and outlet pipes. The bottom of the hole should be undisturbed and level. If leveling is necessary due to overexcavation, use sand for fill.

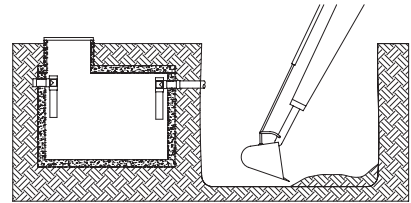

NOTE: Never place tank directly on rock. Place at least six inches of sand bedding between the tank and rock surface.

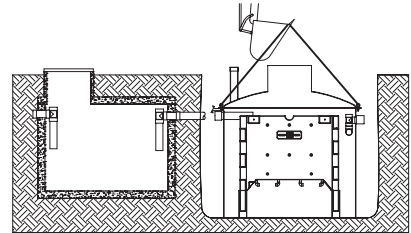

2. TANK PLACEMENT:

Use the backhoe to set the tank. Lifting lugs are furnished to lift the tank.

CAUTION: A small amount of soil or sand should be used around the bottom of the tank to hold it in place. Sand is best. If excavated soil is used, tamp it underneath the tank to provide a good base.

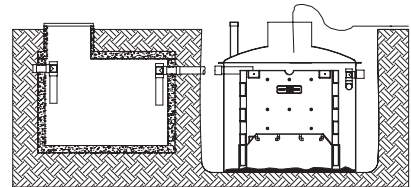

3. FILL TANK WITH WATER:

Place hose in 24" manway or 6" inch riser. Begin filling tank with water.

REV.	DATE	REVISION DESCRIPTION	BY	 delta treatment systems			INSTALLATION PROCEDURE			
<small>COMPANY CONFIDENTIAL: INFORMATION CONTAINED HEREIN IS CONFIDENTIAL. IT IS THE PROPERTY OF DELTA TREATMENT SYSTEMS. IT IS TO BE USED SOLELY FOR THE PURPOSE PROVIDED, AND IT IS NOT TO BE DISCLOSED TO OTHERS WITHOUT THE PRIOR WRITTEN CONSENT OF DELTA TREATMENT SYSTEMS.</small>				PLOT SCALE NTS	DRAWING NUMBER DEP034	DRAWN BY D.WRIGHT	DATE 10/30/07	SHEET OF 1 3	REV A	

4. GFI CONTROLS AND AIR PUMP

Install duplex or quadruple GFI or GFI protected receptacles at the selected location of the air pump. Mount control panel and install fittings, tubing and piping to tank location.

CAUTION: Do not plug anything but the air pump into the control panel.

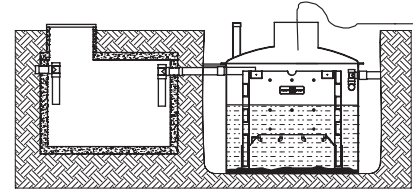

5. INLET/OUTLET AND AIR CONNECTIONS

Properly make solvent cemented inlet, outlet and air connections.

6. FILLING THE TANK

Finish filling tank with water until it drains out of outlet. Begin backfilling with natural soil or a good backfill material.

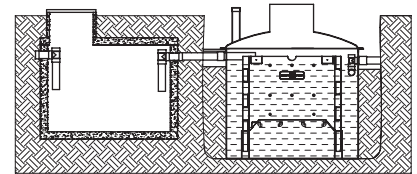

7. AIR DISTRIBUTION

Turn the air pump on and check all air connections and piping for air tightness.

NOTE: If electrical GFI receptacle has not been installed for checking air distribution system during installation, use an extension cord to run the air pump. Never leave the extension cord plugged in. Remove it after inspection is completed.

WARNING: Possible Fire Hazard

Do Not plug into main service equipment on power pole.

Do Not use extension cords.

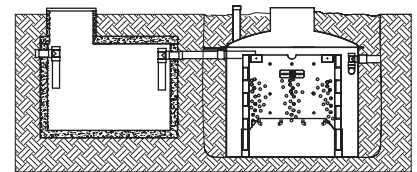

8. FINAL BACKFILLING

Backfill should be mounded above grade slightly to allow for settling. Tamp the backfill beneath the inlet, outlet and air piping to provide good support.

						INSTALLATION PROCEDURE			
REV.	DATE	REVISION DESCRIPTION	BY	PLOT SCALE	DRAWING NUMBER	DRAWN BY	DATE	SHEET OF	REV
				NTS	DEPO34	D.WRIGHT	10/30/07	2 OF 3	A
<small>COMPANY CONFIDENTIAL: INFORMATION CONTAINED HEREIN IS CONFIDENTIAL. IT IS THE PROPERTY OF DELTA TREATMENT SYSTEMS. IT IS TO BE USED SOLELY FOR THE PURPOSE PROVIDED, AND IT IS NOT TO BE DISCLOSED TO OTHERS WITHOUT THE PRIOR WRITTEN CONSENT OF DELTA TREATMENT SYSTEMS.</small>									

9. TRIM INSPECTION RISERS

Trim inspection risers to proper length. The 4" aeration inspection riser also serves as a vent for the tank.

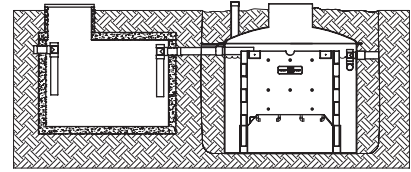

CAUTION: The bottom of the 4" aeration riser must be above the water level for both visual inspection and ventilation. Both of the optional 6" and 4" top caps must be above ground level to prevent groundwater from entering the risers.

CAUTION: Care must be taken not to push the optional 6" Clarifier Inspection Riser down too far. This may cause damage to the effluent discharge tee assembly and the clarifier.

CAUTION: Maximum burial depth for Delta fiberglass tanks – 2 feet from top of tank flange with dome or 24" manways and 1 foot from top of tank flange with flat lids. For burial depths beyond 2 feet, contact the factory. For further details refer to the installation manual.

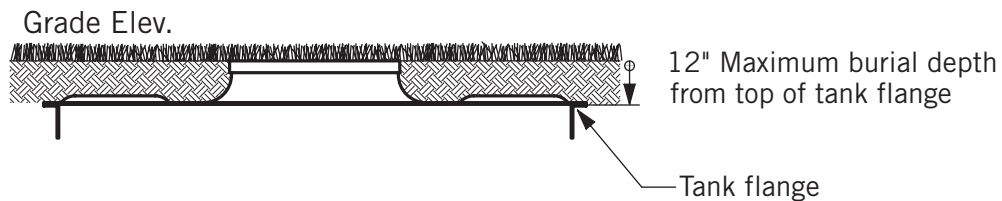
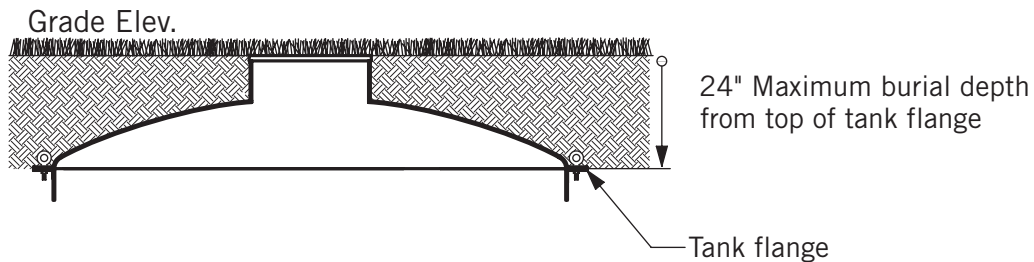

						INSTALLATION PROCEDURE			
REV.	DATE	REVISION DESCRIPTION	BY	PLOT SCALE	DRAWING NUMBER	DRAWN BY	DATE	SHEET OF	REV
				NTS	DEPO34	D.WRIGHT	10/30/07	3 OF 3	A
<small>COMPANY CONFIDENTIAL: INFORMATION CONTAINED HEREIN IS CONFIDENTIAL. IT IS THE PROPERTY OF DELTA TREATMENT SYSTEMS. IT IS TO BE USED SOLELY FOR THE PURPOSE PROVIDED, AND IT IS NOT TO BE DISCLOSED TO OTHERS WITHOUT THE PRIOR WRITTEN CONSENT OF DELTA TREATMENT SYSTEMS.</small>									

TROUBLESHOOTING GUIDE

Air Supply Malfunction

1. Check to be sure air distribution is working properly. This will be evident in the reactor as the liquid will be forcefully agitated. A septic (rotten egg) odor could mean that the system is not getting enough air. If the air system is not working, partially working or working very little (slight bubbles), check the following:
 - a. Check to be sure the air pump is working.
 - Check timer if one is used.
 - Bypass timer temporarily and connect directly to source.
 - Check the electrical source.
 - If electrical source is okay, check service guide on pump unit for troubleshooting information.
 - Wash air filter on pump.
 - Consult manufacturer for servicing information.
 - b. Check to be sure tank is not severely out of level. Air follows a path of least resistance. The pressure differences can be enough to restrict air flow.
 - c. Check for broken or cracked air lines both outside and inside the tank.
 - d. Ants will destroy an air pump. Check to see if there is an ant nest around the air pump.
 - e. Air pump should be protected from rising water.
 - f. Always check to see if inlet and outlet lines are correctly installed.

Internal Assembly Malfunction

1. Primary treated wastewater from the primary tank should not enter directly into the dilution zone because of improperly installed or loose seals or gaskets where pipe goes through the tank wall. Check the size of holes to be sure that there is no clearance for matter to pass through the wall around the piping.
2. Check to be sure all internal piping and connections are tight.

Design Overload

1. The system could be hydraulically overloaded (there is too much water going through the system for the size of the system).
2. The system could be biologically overloaded (there is too much waste for the size of the system).

Improper Installation or Settling

1. You should follow the manufacturer's installation procedures very carefully.
2. Where settling is common, approximately 2" of sand should be placed and tamped in the bottom of the hole.
3. Proper installation is the first step in preventing callbacks for service problems.
4. Whenever possible, it is important to spend time with the homeowner. Be sure they have an operations book. A few minutes invested in the beginning will avoid service calls later.

No Harsh Chemicals Should Be Put into the System

1. Water in the reactor tank should be relatively clear in both the reactor and dilution zones. Blue or gray/blue water indicates heavy use of detergents or other chemicals. If water appears sudsy there is too much detergent being used.
2. Water in the dilution zone should be clear. Water is discharged into the discharge tee at a minimum of 6–8 inches below water surface. You MAY NOT be able to see clear water by looking into the tank. Samples must be taken at the sample port.
3. Oils and grease should be kept to a minimum. Grease tends to form in white balls.

Troubleshooting Electrical System

1. Air pump does not run:
 - a. Check main service for power.
 - b. Check and/or replace fuse with same rating as in control panel.
2. Alarm does not occur when air pump is off:
 - a. Malfunctioning pressure switch – replace.
 - b. Malfunctioning light or buzzer – replace.
3. Alarm occurs continuously even when air pump is running:
 - a. Air leak in main air system or air tubing to pressure switch – repair leak or replace air line.
 - b. Malfunctioning pressure switch – replace.
 - c. High water level in tank – inspect for cause.
 - d. Short in float switch wire or float switches – repair or replace.

NOTE: ALL REPLACEMENT PARTS ARE AVAILABLE FROM YOUR LOCAL DISTRIBUTOR.

⚠ CAUTION: ELECTRICAL SHOCK OR HAZARD MAY OCCUR IF UNIT IS NOT SERVICED PROPERLY. THE MANUFACTURER RECOMMENDS THAT A LICENSED ELECTRICIAN BE CALLED WHEN ELECTRICAL PROBLEMS OCCUR.

COMPONENT REPLACEMENT PROCEDURE

1. **Air Pump** – Follow the same procedure as outlined in the "Installation Instructions."
2. **Float Switch** – Remove Treatment Plant's Riser or 24" cover. Locate float switch cable. Untie knot. Cut float switch cable. Slip float switch cable through rubber grommet into the plant. Replace with exact replacement float switch. Reinstall by reversing the procedure. Reconnect float switch wires using underground rated compound filled wire nuts. **See Float Switch Mounting Details. (Applicable only with float switch option.)**
3. **Pressure Switch** – Turn all power off to the control panel. Remove screws securing pressure switch as well as connectors and tubing. Reverse procedure to install new pressure switch.
4. **Buzzer** – Turn all power off to the control panel. Remove screw attaching buzzer to back plate as well as connectors. Reverse procedure to install new buzzer.
5. **Lamp Holder** – Turn all power off to control panel. Remove lock nut securing lamp holder to door as well as connectors. Remove lamp holder. Install new lamp holder with gaskets furnished. Continue with reverse procedure.

6. **Lamp** – Turn all power off to control panel. Remove red lamp cover from front of control panel. Remove and replace lamp, which is a push-in type. Replace lamp cover and cover gasket.
7. **Fuse** – Turn all power off to control panel. Pull top of fuse holder outward. Remove and replace fuse. Push fuse back into place.
8. **Buzzer Switch** – Turn all power off to control panel. Remove rubber boot on switch. Remove hex nut from switch on panel front as well as connectors on switch. Reverse procedure to install new switch.

GENERAL COMMENTS

1. Only factory approved equipment can be used for replacement on individual treatment systems.
2. If the decision is made to pump out a system, be sure to contact a licensed waste hauler.
3. If a chronic problem develops and all items have been checked, consult with the factory.
4. Taking pictures of systems when troubleshooting will help document activity in the field.
5. Keep good records.

NOTE: IF THE ENTIRE COVER NEEDS TO BE REMOVED ON ANY ONE OF THE VARIOUS MODEL TREATMENT PLANTS, THE EXISTING SILICONE OR STRIP SEAL MUST BE REMOVED AND REPLACED WITH A NEW ONE. THIS WILL PROVIDE A POSITIVE SEAL WHICH WILL NOT ALLOW ANY INFILTRATION INTO OR OUT OF THE TREATMENT PLANT.

ECOPOD-N Unit Specifications

Treatment Plant	Treatment Capacity (GPD)	Minimum Primary Tank Total Volume (Gal)	Reactor Tank Volume (Gal)	Reactor Tank Dilution Volume (Gal)	Media Size	Air Requirements
E50N	500	500	710	590	2'x2'x4'	12 CFM
E60N	600	600	916	736	3'x2'x4'	14.4 CFM
E75N	750	750	1090	910	3'x2'x4'	18 CFM
E100N	1000	1000	1405	1165	4'x2'x4'	24 CFM
E150N	1500	1500	2100	1740	6'x2'x4'	36 CFM

MATERIALS OF CONSTRUCTION

Suffix FF	Reactor Tank Cover Media Container	Fiberglass Fiberglass Polyethylene
Suffix CA	Reactor Tank Cover Media Container	Concrete Concrete Polyethylene
Suffix IM	Reactor Tank Cover Media Container	Polypropylene Polypropylene Polyethylene

These are standard production units. Other configurations are available upon request.

ECOPOD-N Electrical Requirements

Model	Compressor	Motor Full Load Amps	Measured Operating Watts	Electrical Requirements
E50N	Delta Model 06	3.5	185	115 volt – single phase
E60N	Delta Model 06	4.7	280	115 volt – single phase
E75N	Delta Model 06	4.7	280	115 volt – single phase
E100N	Delta Model K03	7.1	475	115 volt – single phase
E150N	Delta Model K03	7.1	475	115 volt – single phase

ECOPOD-N Dimensions

Treatment Plant	A	B	C	D	E	F
E50N	4' 10"	4' 2"	5' 6"	4' 0"	5' 0"	1' 5"
E60N	4' 10"	4' 6"	6' 0"	4' 4"	5' 0"	1' 5"
E75N	5' 7"	4' 11"	6' 3"	4' 9"	5' 9"	1' 6"
E100N	6' 0"	5' 5"	6' 9"	5' 3"	6' 2"	1' 6"
E150N	6' 2"	5' 9"	8' 0"	5' 7"	6' 4"	1' 9"

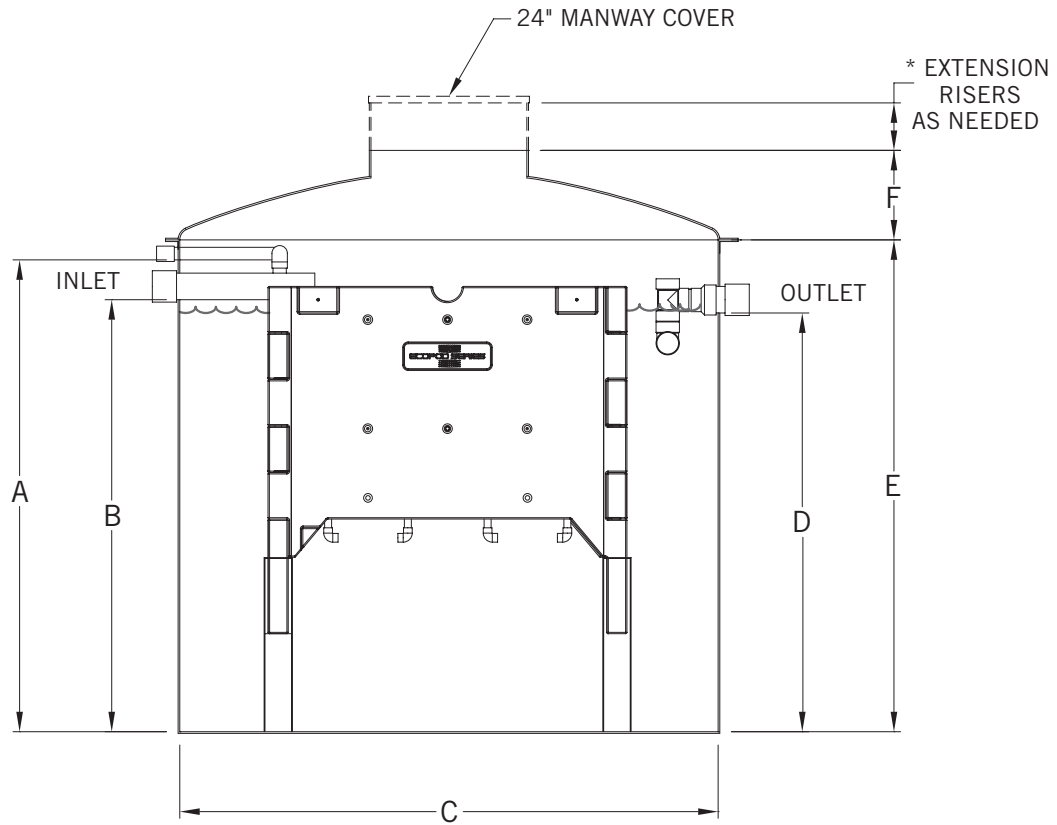

* REFERENCE SHEET 3 OF INSTALLATION
PROCEDURE FOR MAX BURIAL DEPTH

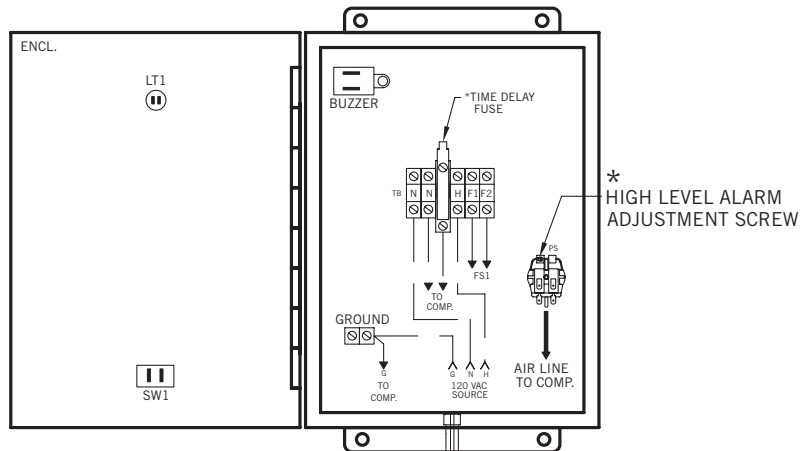

FRONT VIEW
DOOR OPEN
CP22

* SETTING HIGH LEVEL PRESSURE SWITCH

- BRING PLANT TO OPERATING LEVEL WITH COMPRESSOR TURNED ON
- USING PROPERLY SIZED SCREWDRIVER, TURN HIGH LEVEL ALARM ADJUSTMENT SCREW CLOCKWISE UNTIL ALARM OCCURS, THEN TURN THE SCREW COUNTERCLOCKWISE UNTIL ALARM STOPS.

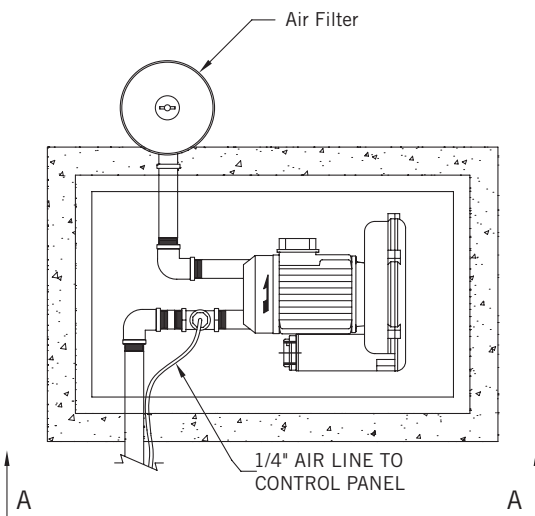

PRESSURE SWITCH TUBING

BLOWER ENCLOSURE

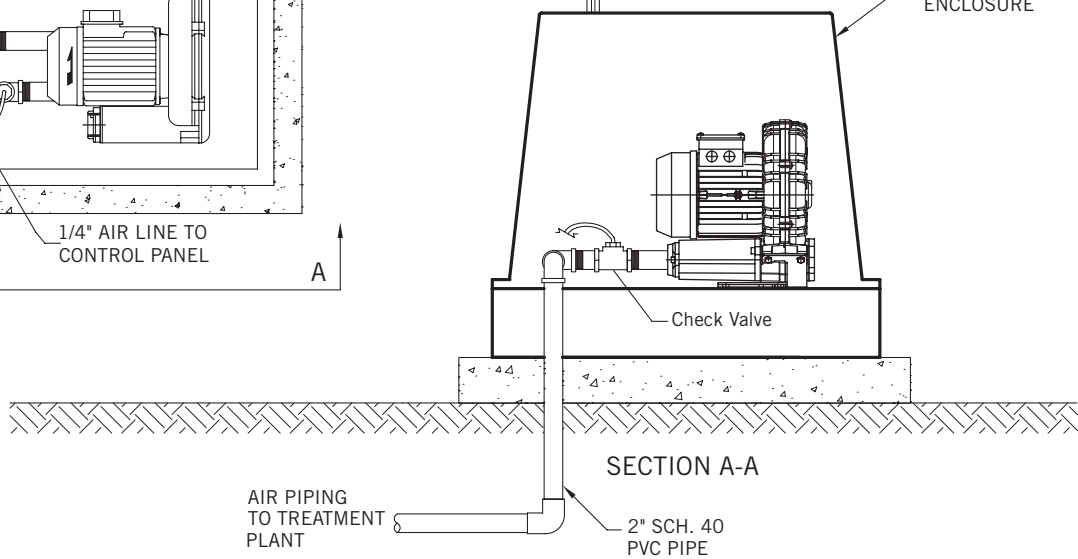

SECTION A-A

AIR PIPING TO TREATMENT PLANT

2" SCH. 40 PVC PIPE

REV.	DATE	REVISION DESCRIPTION	BY



CONTROL PANEL CONNECTION

COMPANY CONFIDENTIAL: INFORMATION CONTAINED HEREIN IS CONFIDENTIAL, IT IS THE PROPERTY OF DELTA TREATMENT SYSTEMS, IT IS TO BE USED SOLELY FOR THE PURPOSE PROVIDED, AND IT IS NOT TO BE DISCLOSED TO OTHERS WITHOUT THE PRIOR WRITTEN CONSENT OF DELTA TREATMENT SYSTEMS.				PLOT SCALE NTS	DRAWING NUMBER CP CON REGEN	DRAWN BY D.WRIGHT	DATE 10/31/07	SHEET OF 1 1	REV B
--	--	--	--	-------------------	--------------------------------	----------------------	------------------	-----------------------	----------

CP2210/ECO/FG/UL CONTROL PANEL
 MAX FULL LOAD AMPS - 8
 VOLTS - 120
 PHASE/HZ - 1/60
 TYPE 4X ENCLOSURE

EXTERNAL DISCONNECT AND
 BRANCH CIRCUIT CONNECTION
 BY OTHERS (20 AMP MAXIMUM)

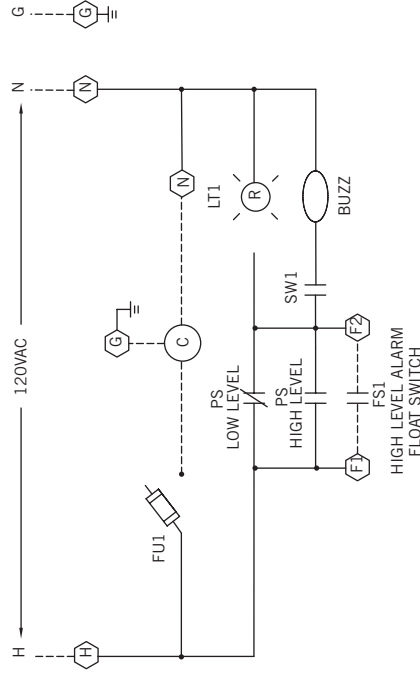

SCHEMATIC DIAGRAM
 CP2210/ECO/FG/UL

SHORT CIRCUIT RATING: 5KA

FUSE SELECTION CHART

MOTOR FULL LOAD CURRENT	TYPICAL TIME DELAY FUSE SIZE REQUIRED	CRT PART NO.
1-4 AMPS	5 AMPS	AE845-4180
4-8 AMPS	10 AMPS	AE845-4184
8-12 AMPS	15 AMPS	AE845-4187
12-16 AMPS	20 AMPS	AE845-4188

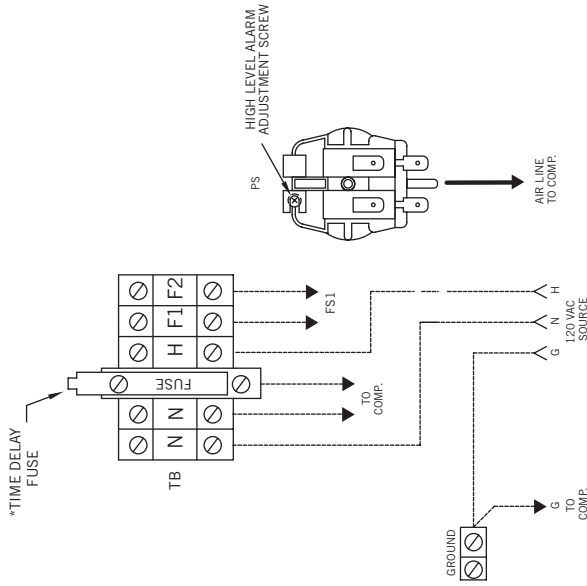

EXTERNAL WIRING

- SETTING HIGH LEVEL PRESSURE SWITCH**
- BRING PLANT TO OPERATING WATER LEVEL WITH COMPRESSOR TURNED ON.
 - USING PROPERLY SIZED SCREWDRIVER, TURN HIGH LEVEL ALARM ADJUSTMENT SCREW COUNTERCLOCKWISE UNTIL ALARM OCCURS.
 - THEN TURN THE SCREW COUNTERCLOCKWISE UNTIL ALARM STOPS.

REV.	DATE	REVISION DESCRIPTION	BY

COMPANY CONFIDENTIAL INFORMATION CONTAINED HEREIN IS CONFIDENTIAL. IT IS THE PROPERTY OF DELTA TREATMENT SYSTEMS, IT IS TO BE USED SOLELY FOR THE PURPOSE PROVIDED, AND IT IS NOT TO BE DISCLOSED TO OTHERS WITHOUT THE PRIOR WRITTEN CONSENT OF DELTA TREATMENT SYSTEMS.



CP2210 SCHEMATIC

PLOT SCALE NTS	DRAWING NUMBER CP2210	DRAWN BY D.WRIGHT	DATE 10/03/07	SHEET OF 1 OF 1	REV A
-------------------	--------------------------	----------------------	------------------	-----------------------	----------

CP2220/ECO/FG/UL CONTROL PANEL
 MAX FULL LOAD AMPS - 8
 VOLTS - 120
 PHASE/HZ - 1/60
 TYPE 4X ENCLOSURE

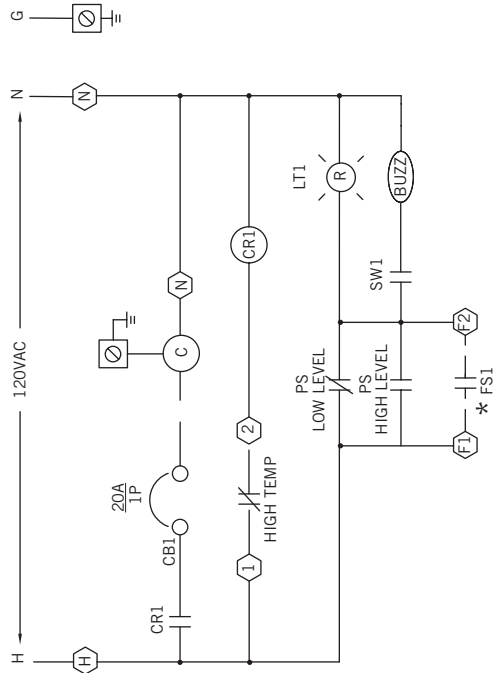

SCHMATIC DIAGRAM
 CP2220/ECO/FG/UL

SHORT CIRCUIT RATING: 5KA

* FS1 - H.L. - FLOAT SWITCH
 IN TREATMENT PLANT
 - A SEPARATE DISCONNECT
 IS REQUIRED.

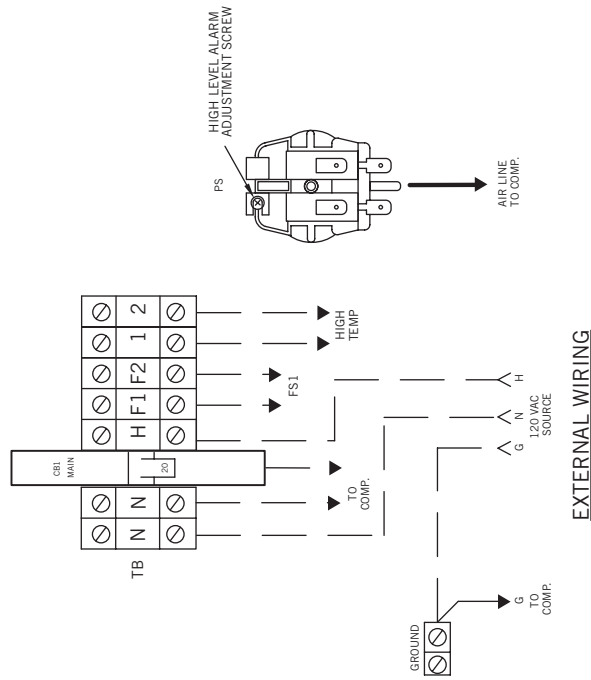

EXTERNAL WIRING

SETTING HIGH LEVEL PRESSURE SWITCH

- BRING PLANT TO OPERATING WATER LEVEL WITH COMPRESSOR TURNED ON.
- USING PROPERLY SIZED SCREWDRIVER, TURN HIGH LEVEL ALARM ADJUSTMENT SCREW COUNTERCLOCKWISE UNTIL ALARM OCCURS.
- THEN TURN THE SCREW COUNTERCLOCKWISE UNTIL ALARM STOPS.

REV.	DATE	REVISION DESCRIPTION	BY



CP2220 SCHEMATIC

COMPANY CONFIDENTIAL: INFORMATION CONTAINED HEREIN IS CONFIDENTIAL, IT IS THE PROPERTY OF DELTA TREATMENT SYSTEMS, IT IS TO BE USED SOLELY FOR THE PURPOSE PROVIDED, AND IT IS NOT TO BE DISCLOSED TO OTHERS WITHOUT THE PRIOR WRITTEN CONSENT OF DELTA TREATMENT SYSTEMS.

PLOT SCALE
 NTS

DRAWING NUMBER
 CP2220

DRAWN BY
 D.WRIGHT

DATE
 10/30/07

SHEET
 OF
 1 OF 1

REV
 A

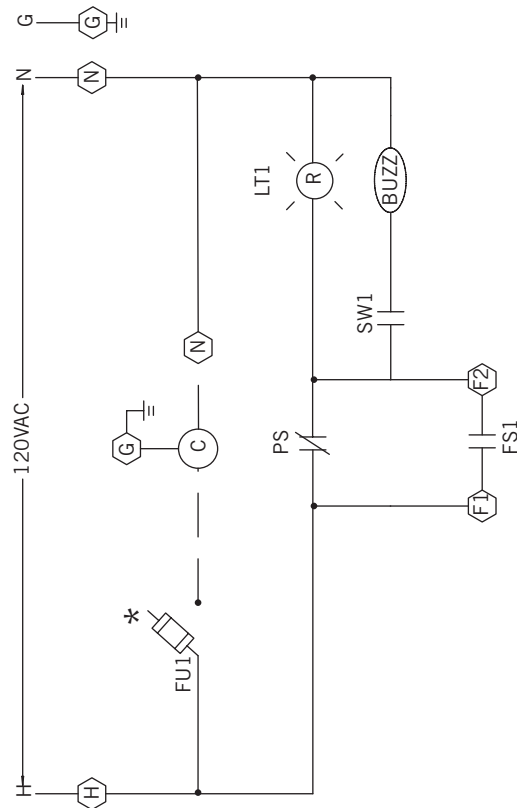
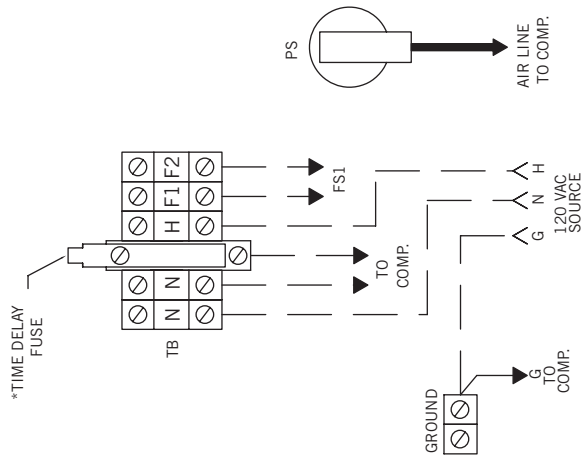

SCHEMATIC DIAGRAM
CP20 SERIES

* FUSE SIZE VARIES WITH COMPRESSOR SIZE
PER NATIONAL ELECTRICAL CODE

				CP20 SCHEMATIC					
REV.	DATE	REVISION DESCRIPTION	BY	PLOT SCALE	DRAWING NUMBER	DRAWN BY	DATE	SHEET OF	REV
				NTS	CP20	D.WRIGHT	04/09/03	1 OF 1	A
<small>COMPANY CONFIDENTIAL: INFORMATION CONTAINED HEREIN IS CONFIDENTIAL, IT IS THE PROPERTY OF DELTA TREATMENT SYSTEMS, IT IS TO BE USED SOLELY FOR THE PURPOSE PROVIDED, AND IT IS NOT TO BE DISCLOSED TO OTHERS WITHOUT THE PRIOR WRITTEN CONSENT OF DELTA TREATMENT SYSTEMS.</small>									

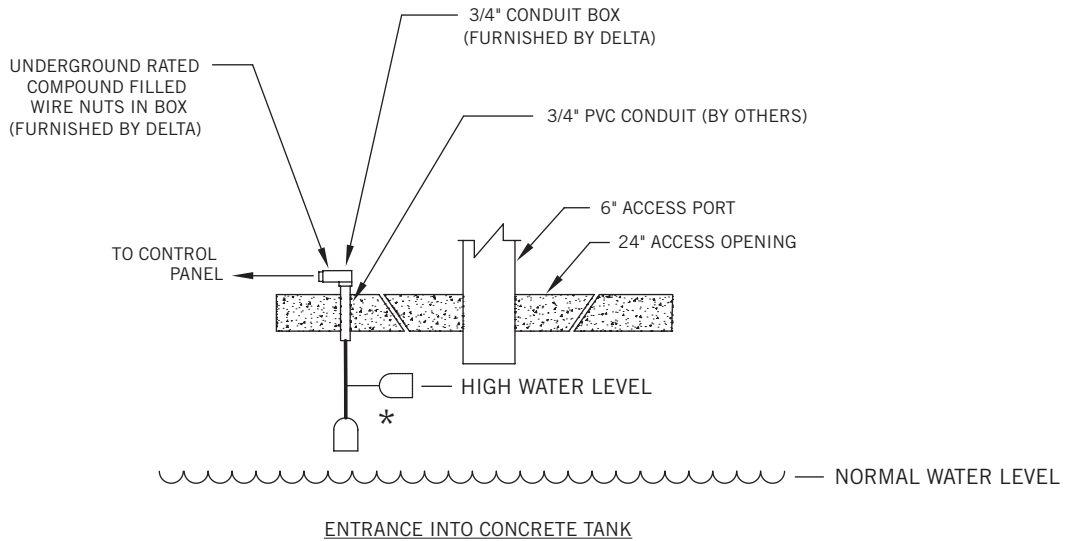
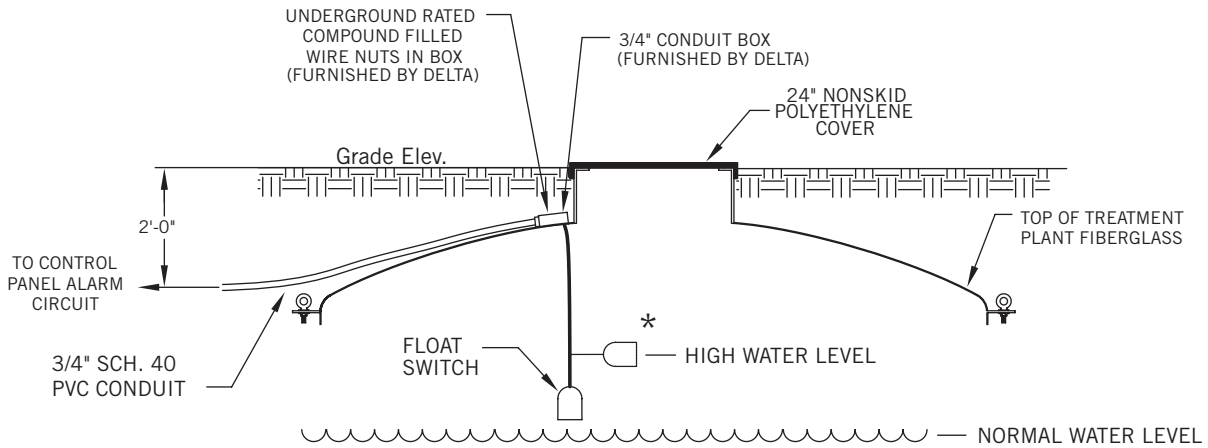

NOTES:

1. GROMMET TO BE SELECTED FOR TIGHT FIT AROUND CABLE AND IN LID.
2. WIRE TO CONTROL PANEL TO BE 18 GAUGE AND RATED FOR DIRECT BURIAL SERVICE. WOODS WIRE-886 OR EQUAL.
3. WIRE NUTS TO BE RATED FOR UNDERGROUND SERVICE IDEAL-DB PLUS MODEL 60 OR EQUAL.
4. FLOAT SWITCH TO BE NORMALLY OPEN MDI-2900-B8S13B OR EQUAL.
5. SMALL ACCESS PORT SHOWN ON DRAWING; LARGE ACCESS PORTS MAY BE SUPPLIED.
6. MINIMUM AMOUNT OF CONDUIT SHOWN ABOVE IS REQUIRED EVEN WITH TYPE UF CABLE.

* HIGH LEVEL FLOAT NOT REQUIRED WHEN USING CP22 SERIES CONTROL PANELS

						FLOAT SWITCH MOUNTING (TO USE W/ CP20 PANEL)			
REV.	DATE	REVISION DESCRIPTION	BY	PLOT SCALE	DRAWING NUMBER	DRAWN BY	DATE	SHEET OF	REV
				NTS	DWG NO	D.WRIGHT	05/18/09	1 OF 1	A
<small>COMPANY CONFIDENTIAL: INFORMATION CONTAINED HEREIN IS CONFIDENTIAL, IT IS THE PROPERTY OF DELTA TREATMENT SYSTEMS, IT IS TO BE USED SOLELY FOR THE PURPOSE PROVIDED, AND IT IS NOT TO BE DISCLOSED TO OTHERS WITHOUT THE PRIOR WRITTEN CONSENT OF DELTA TREATMENT SYSTEMS.</small>									



F.P.Z. GmbH
 Kilianstraße 142
 90425 NÜRNBERG
 Tel. 0911.36.76.68.00
 Fax 0911.36.76.68.01
 E-mail deutschland@fpz.com

LATERAL CHANNEL BLOWERS - EXHAUSTERS

SCL 06 MOR

SN 1750-0

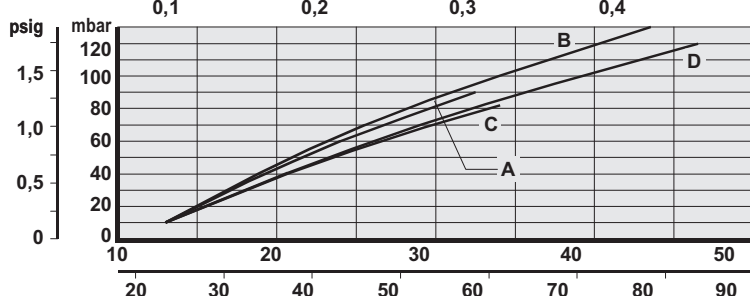
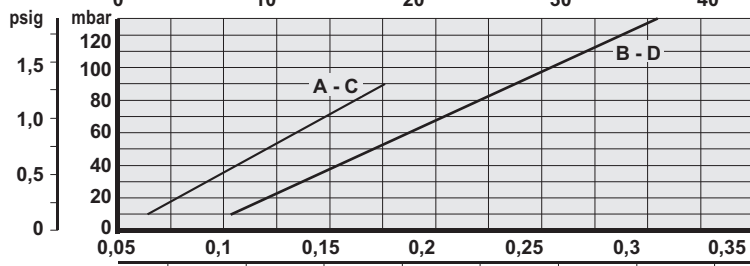
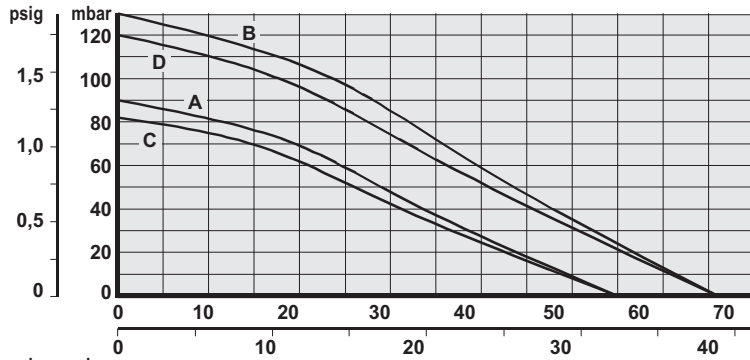

P ⁽¹⁾ kW	Δp ⁽²⁾ mbar psig	Q ⁽³⁾ m³/h cfm
------------------------	--------------------------------	------------------------------

COMPRESSOR

A	50 Hz - 2900 rpm			
0.2	90	1.30	0	0

B	60 Hz - 3500 rpm			
0.23	80	1.16	32	19
0.4	130	1.88	0	0

EXHAUSTER

C	50 Hz - 2900 rpm			
0.2	82	1.18	0	0

D	60 Hz - 3500 rpm			
0.23	80	1.16	28	16
0.4	120	1.74	0	0

kW	H	m
50 Hz - 60 Hz		Kg
0.2 - 0.23	235	6.5
0.4	235	7.1

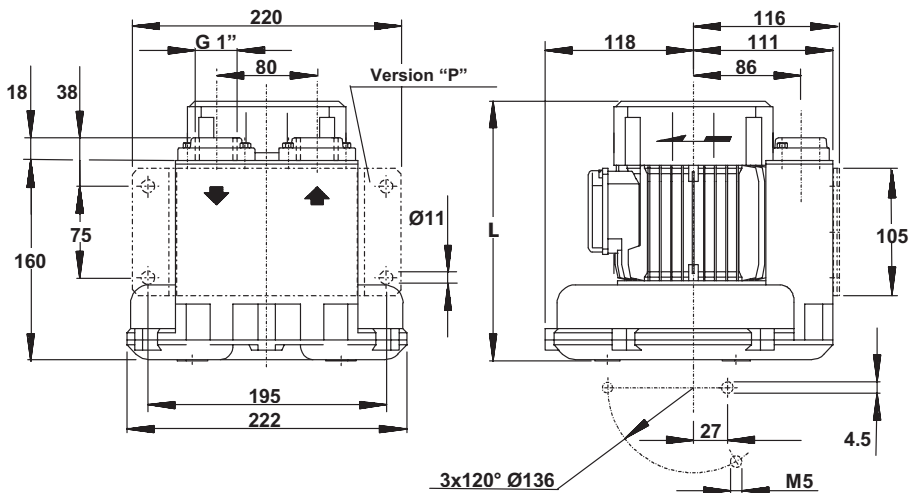

MAXIMUM NOISE LEVEL	
	Lp dB(A)
50 Hz - 2900 rpm	58
60 Hz - 3500 rpm	59

To allow the perfect performing of the machine, it has to be equipped with the INLET FILTER and the SECURITY VALVE AT LEAST; other accessories available on request.

- (1) Installed power.
- (2) Maximum differential pressure referred to installed motor.
- (3) Inlet flow at max differential pressure per installed motor.

The characteristics data given, refer to the handling of gas with inlet temperature of 15°C, normal density of 1,23 kg/m³ and absolute pressure of 1013 mbar in suction in case of performing as compressor, in discharge in case of performing as exhauster. Dimensions in mm. Noise level measured at 1 m distance with in/outlets piped. Tolerance on given values ±10% - unbinding and can be changed without prior notice.



FPZ, Inc
 150 N. Progress Drive
 Saukville, WI 53080 - U.S.A.
 Tel. (262) 268-0180
 Fax (262) 268-0415
 E-mail usa@fpz.com

REGENERATIVE BLOWERS - PRESSURE
SCL K03 / K04 / K05 / K06
MS SERIES - MOR RANGE
 SN 1874-8 1/2

TECHNICAL CHARACTERISTICS

- Aluminum alloy construction
- Smooth operation
- High efficiency impeller
- Maintenance free
- Mountable in any position
- Recognized TEFC - cURus motor

OPTIONS

- Special voltages (IEC 38)
- Surface treatments

ACCESSORIES

- Inlet and/or inline filters
- Additional inlet/outlet silencers
- Safety valves
- Flow converting device
- Optional connectors

Dimensions in inches.

Dimension for reference only.

Possible alternative positions,
 please refer to drw SI 1839

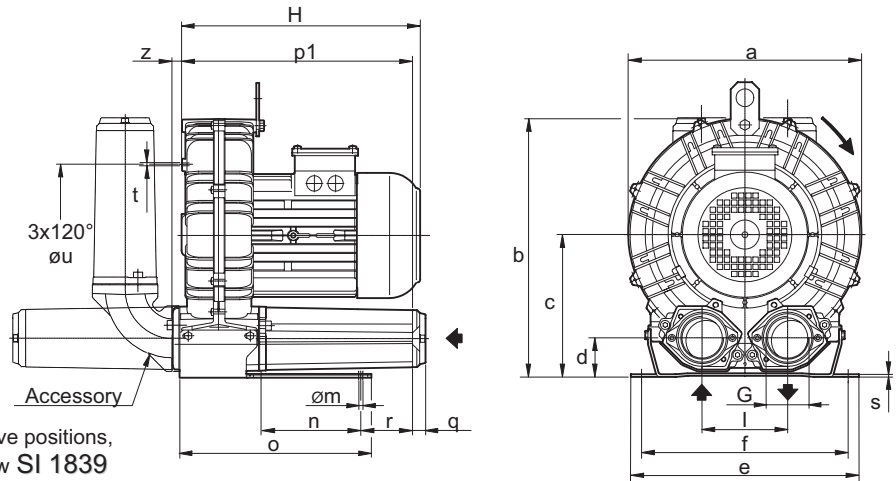

Model	a	b	c	d	e	f	G	l	m	n	o	p1	q	r	s	t	u	z
K03-MS	9.49	10.55	5.79	1.69	9.06	8.07	1 1/4 NPT	3.39	0.39	3.27	5.59	8.07	0.71	2.95	0.16	M6	5.51	0.47
K04-MS	11.22	12.40	6.77	1.93	10.04	8.86	1 1/2 NPT	4.02	0.47	3.74	6.73	8.74	0.71	2.76	0.16	M6	6.89	0.71
K05-MS	12.87	14.37	7.87	2.13	12.60	10.24	2" NPT	4.72	0.59	4.53	10.43	12.60	0.71	3.86	0.16	M8	7.87	0.75
K06-MS	14.80	15.47	8.07	2.13	12.80	11.42	2" NPT	4.92	0.59	5.51	10.71	13.15	0.71	3.35	0.16	M8	9.45	0.75

Model	Maximum flow Scfm		Installed power Hp		Maximum differential pressure Δp (In WG)		Noise level Lp dB (A) ⁽¹⁾		Overall dimensions H	Weight
	60 Hz	50 Hz	60 Hz	50 Hz	60 Hz	50 Hz	60 Hz	50 Hz		
	3500 rpm	2900 rpm	3500 rpm	2900 rpm	3500 rpm	2900 rpm	3500 rpm	2900 rpm	Inches	Lbs
K03-MS	52	43	3/4	3/4	64	60	62.0	60.0	10.43	24.30
			1	1	95	77	62.3	60.3	11.97	26.50
K04-MS	98	81	1 1/2	1 1/2	58	80	64.8	62.8	11.65	36.40
			2	2	85	100	65.0	63.0	13.78	43.00
			3	-	120	-	65.2	-	13.78	49.60
K05-MS	156	129	2	2	52	70	70.5	68.5	13.20	51.80
			3	3	90	110	70.8	68.8	13.20	58.40
			4	4	128	120	71.1	69.1	14.40	67.20
K06-MS	216	179	3	3	50	65	73.0	71.0	13.54	68.70
			4	4	75	95	73.3	71.3	14.17	71.65
			5 1/2	5 1/2	110	140	73.6	71.6	14.17	77.60
			6 1/5 ⁽²⁾	-	132	-	73.9	-	14.45	77.60

(1) Noise measured at 1 m distance with inlet and outlet ports piped, in accordance to ISO 3744.

(2) No cURus motor

- For proper use, the blower should be equipped with inlet filter and safety valve; other accessories available on request.
- Ambient temperature from +5° to +104°F.
- Specifications subject to change without notice.



REGENERATIVE BLOWERS - PRESSURE
SCL K03 / K04 / K05 / K06
MS SERIES - MOR RANGE
 SN 1874-8 2/2

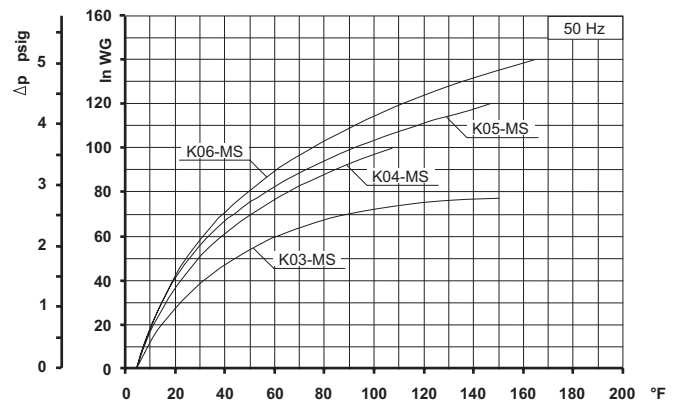
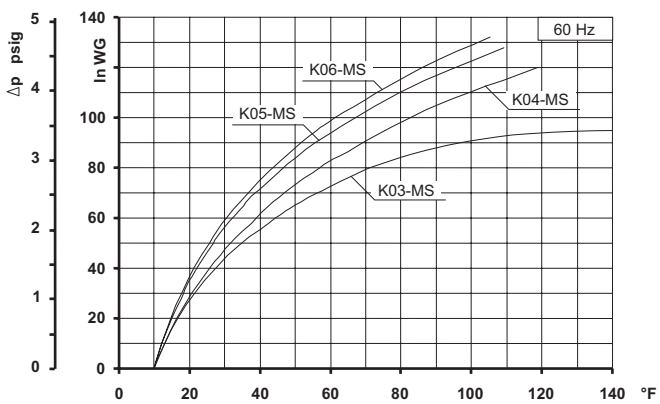
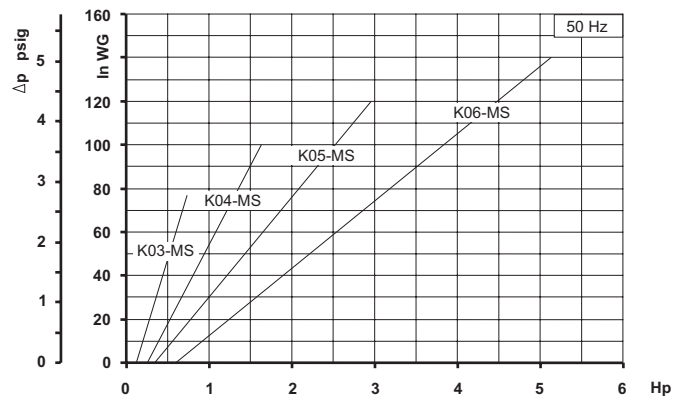
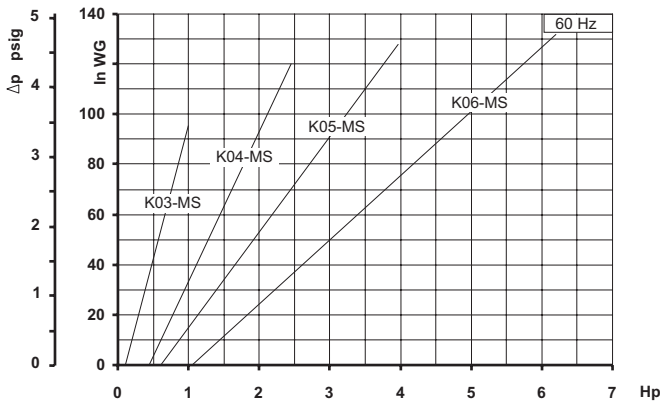
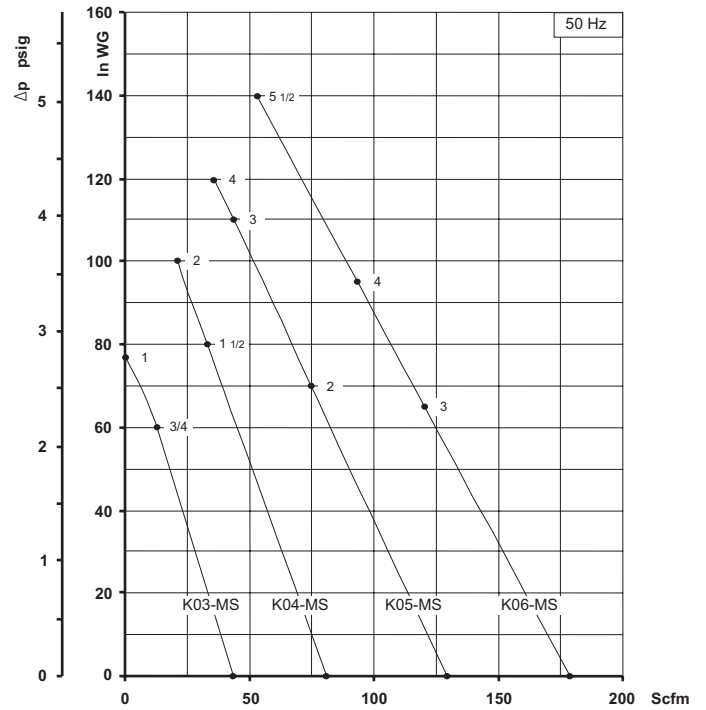
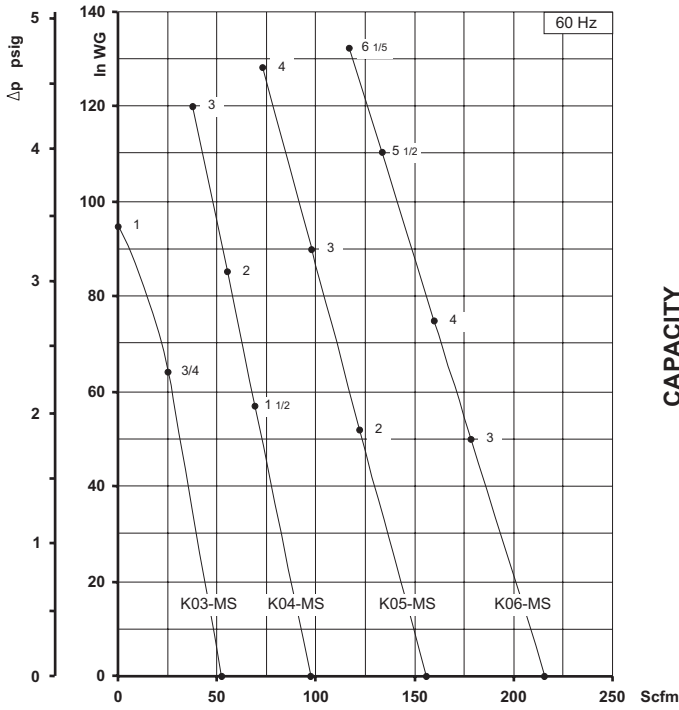

Curves refer to air at 68°F temperature and 29.92 In Hg atmospheric pressure (abs) measured at inlet port.
 Values for flow, power consumption and temperature rise: +/-10% tolerance.
 Data subject to change without notice.

ECOPOD-N SERIES DATA PLATES



ECOPOD-N SERIES
Delta Treatment Systems, LLC
9125 Comar Drive
Walker, LA 70785
Phone: 1-800-219-9183
Model E XXX-XX
XXX GPD Class I



Certified to NSF/ANSI Standards 40 & 245

Serial No. XX-XXXXXXXX



ECOPOD-N SERIES
Delta Treatment Systems, LLC
9125 Comar Drive
Walker, LA 70785
Phone: 1-800-219-9183
Model E XXX-XX
XXX GPD Class I



Certified to NSF/ANSI Standards 40 & 245

Serial No. XX-XXXXXX XX



DELTA TREATMENT SYSTEMS INDIVIDUAL MECHANICAL WASTEWATER TREATMENT SYSTEM SERVICE POLICY

INITIAL POLICY:

A two-year initial service policy shall be furnished to the user by the manufacturer or the distributor through the dealer. This policy may be included in the price of the system, provided the state in which the system is being installed has adapted NSF Policies as part of their state rules

1. **An inspection/service call every six months**, which includes inspection, adjustment, and servicing of the mechanical and electrical component parts as necessary to ensure proper function.
2. An effluent quality inspection every six months consisting of a visual check for color, turbidity, scum overflow, and an examination for odors.
3. If any improper operation is observed that cannot be corrected at that time, the user shall be notified immediately in writing of the conditions and the estimated date of correction. **THIS POLICY DOES NOT INCLUDE PUMPING SLUDGE FROM UNIT IF DEEMED NECESSARY.**

CONTINUING SERVICE POLICY:

An annually renewable service policy affording the same coverage as the Initial Service Policy is available. Consult your dealer for pricing information.

PARTS:

Replacement parts or components may be obtained from your local distributor or contact Delta Treatment Systems for information.

COMPLAINTS:

In order for Delta Treatment Systems to properly address complaints, we require that you put in writing the date and nature of the complaint as detailed as possible. This **MUST** include the serial number of your system.

Send to: Delta Treatment Systems
9125 Comar Drive
Walker, LA 70785

THIS PAGE INTENTIONALLY LEFT BLANK

THIS PAGE INTENTIONALLY LEFT BLANK

DELTA TREATMENT SYSTEMS, LLC ("DELTA")

DELTA TWO (2) YEAR Ecopod® SERIES MATERIALS AND WORKMANSHIP LIMITED WARRANTY

- (a) This limited warranty is extended to the end user of a Delta Ecopod® Series Advanced Wastewater Treatment Product (the "Ecopod® Product"). An Ecopod® Product manufactured by Delta, when installed and operated in accordance with Delta's installation instructions and local regulation by a licensed installer, is warranted to you: (i) against defective materials and workmanship for two (2) years after installation. Delta will, at its option, (i) repair the defective product or (ii) replace the defective materials. This Warranty does not cover any damage caused by flooding, abuse, unauthorized disassembly, improper wiring or overload protection. This Warrant does not cover any of the house wiring, plumbing, drainage or disposal systems.
- (b) In order to exercise your warranty rights, you must notify Delta in writing at its corporate headquarters in Walker, Louisiana within fifteen (15) days of the alleged defect. Delta reserves the right to inspect the item to confirm that it is defective.
- (c) YOUR EXCLUSIVE REMEDY WITH RESPECT TO ANY AND ALL LOSSES OR DAMAGES RESULTING FROM ANY CAUSE WHATSOEVER SHALL BE SPECIFIED IN SUBPARAGRAPH (a) ABOVE. DELTA SHALL IN NO EVENT BE LIABLE FOR ANY CONSEQUENTIAL OR INCIDENTAL DAMAGES OF ANY KIND, HOWEVER OCCASIONED, WHETHER BY NEGLIGENCE OR OTHERWISE. SOME STATES DO NOT ALLOW THE EXCLUSION OR LIMITATION OF INCIDENTAL OR CONSEQUENTIAL DAMAGES, SO THIS LIMITATION OR EXCLUSION MAY NOT APPLY TO YOU. THIS WARRANTY GIVES YOU SPECIFIC LEGAL RIGHTS AND YOU MAY ALSO HAVE OTHER RIGHTS WHICH VARY FROM STATE TO STATE.
- (d) THIS LIMITED WARRANTY IS THE EXCLUSIVE WARRANTY GIVEN BY DELTA AND SUPERSEDES ANY PRIOR, CONTRARY, ADDITIONAL, OR SUBSEQUENT REPRESENTATIONS, WHETHER ORAL OR WRITTEN. DELTA DISCLAIMS AND EXCLUDES TO THE GREATEST EXTENT ALLOWED BY LAW ALL OTHER WARRANTIES, WHETHER EXPRESS OR IMPLIED, OR STATUTORY, INCLUDING ANY WARRANTY OF MERCHANTABILITY, FINESSE FOR A PARTICULAR PURPOSE AND ANY IMPLIED WARRANTIES OTHERWISE ARISING FROM COURSE OF DEALING, COURSE OF PERFORMANCE, OR USAGE OF TRADE. NO PERSON (INCLUDING ANY EMPLOYEE, AGENT, DEALER, OR REPRESENTATIVE) IS AUTHORIZED TO MAKE ANY REPRESENTATION OR WARRANTY CONCERNING THIS PRODUCT, EXCEPT TO REFER YOU TO THIS LIMITED WARRANTY. EXCEPT AS EXPRESSLY SET FORTH HEREIN, THIS WARRANTY IS NOT A WARRANTY OF FUTURE PERFORMANCE, BUT ONLY A WARRANTY TO REPAIR OR REPLACE DEFECTIVE COMPONENTS.
- (e) YOU MAY ASSIGN THIS LIMITED WARRANTY TO A SUBSEQUENT PURCHASER OF YOUR HOME.
- (f) NO REPRESENTATIVE OF DELTA HAS THE AUTHORITY TO CHANGE THIS LIMITED WARRANTY IN ANY MANNER WHATSOEVER, OR TO EXTEND THIS LIMITED WARRANTY BEYOND THE STATED TWO (2) YEAR TERM.
- (g) NO WARRANTY OF ANY KIND IS MADE WITH REGARD TO ANY PRODUCT, COMPONENTS, DEVICES, MEDIA OR TREATMENT UNITS WHICH ARE MANUFACTURED BY OTHERS AND ARE INSTALLED IN CONNECTION WITH THE ECOPOD® PRODUCT. USE OF THESE PRODUCTS ARE AT YOUR OWN RISK.

CONDITIONS AND EXCLUSIONS

There are certain conditions or applications over which Delta has no control. Defects or problems as a result of such conditions or applications are not the responsibility of Delta and are NOT covered under this warranty. They include failure to install the Ecopod® Product in accordance with instructions or applicable regulatory requirements or guidance and altering the Ecopod® Product contrary to the installation instructions.



DELTA TREATMENT SYSTEMS, LLC

9125 Comar Drive, Walker, LA 70785

225-665-6162 • 1-800-219-9183 • www.deltatreatment.com